



Three phase asynchronous motors are used in industry due to its simple construction and low maintenance operation. However, torque and motor current during the starting of a three-phase asynchronous squirrel-cage motor is usually not very favorable. Therefore electronic starters, like EMS, are used to reduce the excessively high starting currents. By limiting the accelerating torque, mechanical stress on the material to be conveyed or processed, and consequently on all mechanical parts of drive and driven machine, is reduced. By starting motor at low voltage and avoiding large current peaks during starting with current limit feature, the cost of electricity may also be reduced.



MODELS

**D3 EMS1,
EMS2000,
EMS-MMI**

FEATURES

- Suitable for motor ratings from 2HP -75 HP
- Soft start and Soft stop
- Reduced voltage start with current limit
- Various modes of starting
- MMI (Man Machine Interface) along with PC communication
- Equipped with important motor protection functions
- True RMS Measurement and display of electrical parameters

Ordering Instructions

- Product Family Name
- Model Name
- System Supply
- Aux. Supply/Control supply voltage
- Motor rating (HP /KW)
- Motor applications

SOFT STARTERS

EMS 2000



Minilec introduces a new range of Electronic Motor Starter - EMS-2000. These newly introduced Electronic Soft Starter are packed with unique features and are designed for a stand-alone applications.

EMS 2000 is equipped with various options for Starting as per load types and also offers protection to motor.



Power Range (KW / HP)	From 7.5 KW/10 HP Up to 55 KW/75 HP
Nominal Current (Amp)	16 Amps. - 96 Amps. (Max)
Aux. Supply Voltage	In-Built
System Supply	415V AC (-20% + 15%)
Line Frequency	50 Hz \pm 3%
Bypass facility	External Contactor
Start Mode	Normal High Volt Start Normal Low Volt Start Short Kick with Low Volt start Short Kick with High Volt start Long Kick with Low Volt start Long Kick with High Volt start
Current Limit % In (FLA)	Range 150% to 350% of In (POT)
Ramp Up Time (Sec.)	1, 5, 10, 15, 20, 30, 45, 60 sec.
Ramp Down Time (Sec.)	Twice of start time
Protections	Single Phase, Reverse Phase SCR Short / Open, Unit overheat Overload (IDMTL), Class 2 in run Under Voltage, Lock Rotor 5 * IL < 5ms
Operating Temp.	0 to 45°C
Dimensions Overall (L x W x D)	Please see table below
Mounting (L x W)	
Weight in Kgs (Approx.)	
Communication	N.A.
Protocol	N.A.

Protections

- Electronic over load protection - Adjustable range : 40% - 100% (100% = 5A, i.e. secondary of external CT)
- Under voltage (-20% \pm 1% of system supply)
- SCR short/open fault protection 3.5 \pm 1.5 sec
- Single phase protection 3.5 \pm 1.5 sec
- Reverse phase protection 3.5 \pm 1.5 sec
- Locked Rotor (for current above 500% to trip within 5 Sec.
- Heat - sink over temperature (75° C \pm 5° C)

Faults and Indications

To understand the fault indications refer following table.

Fault	LED	Indication
Overload	Under voltage / overload	Flashing
Lock rotor	Under voltage / overload	Flashing
Heat sink over Temperature	Under voltage / overload	Flashing
Under voltage	Under voltage / overload	Steady ON
SCR short	Single phase / SCR fault	Flashing
SCR open	Single phase / SCR fault	Flashing
Single phase	Single phase / SCR fault	Steady ON
Reverse phase	Trip relay ON	Steady ON

- Start
- Stop (soft stop also valid in by- pass mode)
- Emergency stop / system reset (free run to stop)

Relay output

- Mains relay
- By pass Contactor relay
- Trip relay

Typical fields of application for "EMS 2000" include.

- Electrical drives for processing materials which are sensitive to jerking and pulling.
- Pump drives.
- Drives with long periods of operation under no-load condition.
- Machines with transmission systems, belt or chain drives.
- Drives with large inertia.

Typical equipment used with the EMS 2000 are :

- Fans
- Blowers
- Compressors
- Centrifugal pumps
- Conveyor belts
- Cranes (OH)

Controls (External / Remote)

Features

- Soft Start - Adjustable soft start time range : 1 - 60 sec.
- Soft Stop - Twice of start time
- Normal high volt start.
- Kick start
- Adjustable kick duration 400/800 ms.
- Current limit: Adjustable range : 150%-350% of FLA, (100% = 5A, of secondary of external CT)
- Energy save (PFC)
- By pass Enable/Disable

Normal Low Volt Start (without Kick)

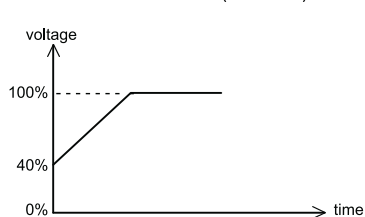

Normal High Volt Start (without Kick)

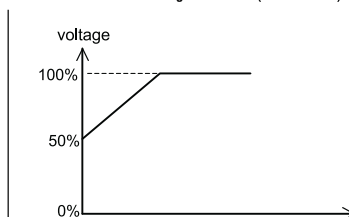

Short Duration Kick With High Volt Start

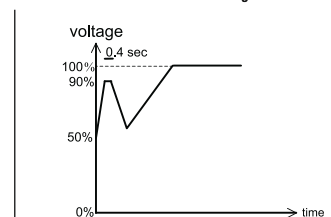

Size, Mounting & Weight

Model	Size (LxWxD) in mm	Mounting (LxW) in mm	Weight in kgs
10HP-20HP	392x223x195	350x170	9.0
30HP-40HP	392x223x235	350x170	11.3
50HP-60HP	392x223x235	350x170	12.0
75HP	415x223x250	395x170	16.5

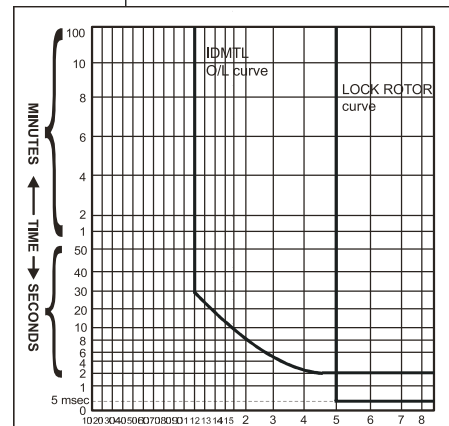
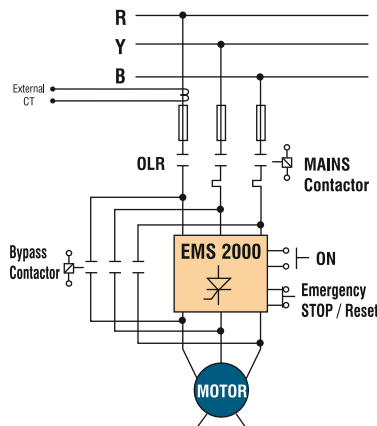

SOFT STARTERS



EMS-MMI

This is an advanced version of EMS 2000 with Man Machine Interface.

It displays true RMS value of electrical parameters and motor status along with motor run hours. The programming facility enables easy & user friendly settings

EMS-MMI offers all important protections to the motor. All Parameters & events can be Communicated to PC for data logging.



Power Range (KW / HP)	7.5 KW / 10 HP
Nominal Current (Amp)	16 Amp.
Aux. Supply Voltage	90-270V AC / DC
System Supply	415V AC -20%+15%, 3 Ph, 4 Wire
Line Frequency	50 Hz ± 3%
Bypass facility	External Contactor
Start Mode	Normal High Volt Start Normal Low Volt Start Short Kick with Low Volt start Short Kick with High Volt start Long Kick with Low Volt start Long Kick with High Volt start
Current Limit % In (FLA)	Range 150% to 350% of FLA
Ramp Up Time (Sec.)	1 to 60 sec
Ramp Down Time (Sec.)	1 to 60 sec
Protections (fix)	Single Phase, Reverse Phase SCR Short / Open, Unit overheat, Programmable Overload (IDMTL) Class 10/10 A 40% to 100% of FLA Under Voltage (320-400 V) Over Voltage (400-500 V) Lock Rotor 5 * IL < 1sec
Operating Temp.	0 to 45°C
Device Dimensions	350 x 210 x 195 mm.
Weight (Approx.)	10 Kg.
Communication	RS 232 / RS 485
Protocol	MODBUS ASCII / RTU

Displays	<ul style="list-style-type: none"> 4 Digit, 7 Segment 	Input Voltage (true RMS) Motor Current (true RMS) Supply Frequency Kilowatt (run Mode Only) Motor Run Hour Heatsink Temperature Vin, Amp, Hz, Kw, M-hr, °c
<ul style="list-style-type: none"> LED 	<ul style="list-style-type: none"> Programming Keys Control Keys 	Up, Shift, Escape, Enter
Digital Inputs & Outputs	<ul style="list-style-type: none"> Local Remote 	Soft Start, Soft Stop, Fault Reset, Emergency Stop. Soft Start, Soft Stop, Fault Reset, Emergency Stop
<ul style="list-style-type: none"> Relay Output (1 NO) (resistive - 5 A 230 Vac & 5 A 30 Vdc) 	<ul style="list-style-type: none"> Relay Output (1 NO) (resistive - 5 A 230 Vac & 5 A 30 Vdc) 	Mains On Relay, Bypass Relay, Trip Relay
Communication	<ul style="list-style-type: none"> Mode Protocols Baud Rate Device Address 	RS 232 (default) / RS 485 Local, Monitor (default) Modbus - ASCII (default) / RTU 1200 / 4800 / 9600 (default) / 19200 / 38400 1 To 32 (in Steps of 1 Unit)

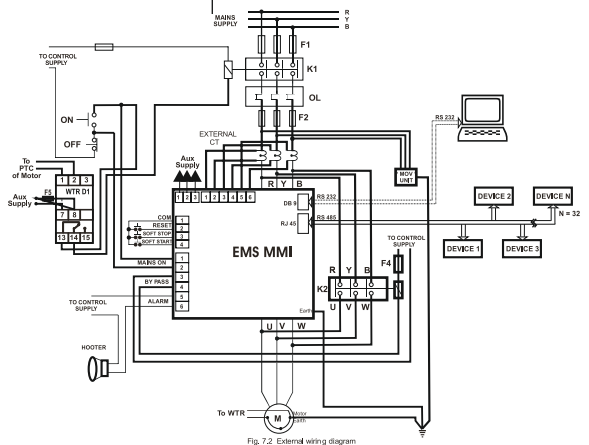
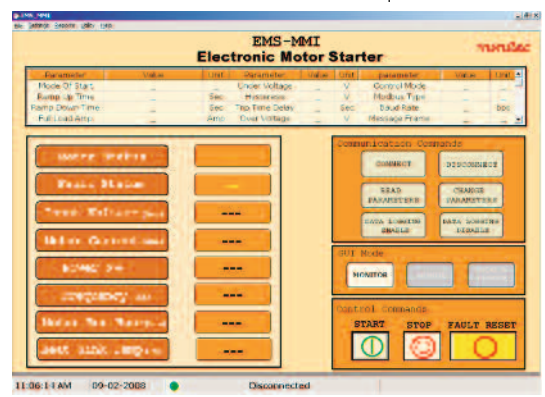
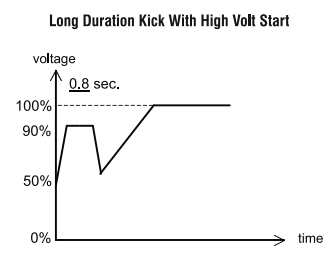
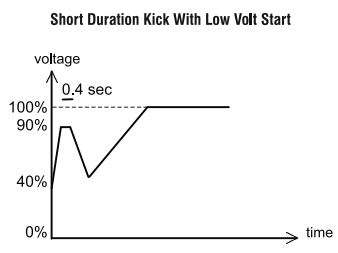
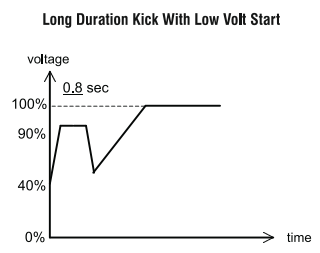
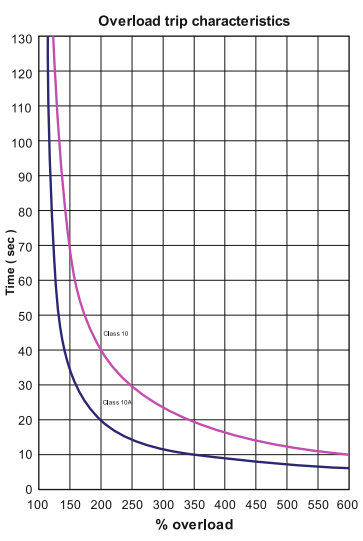

SOFT STARTERS

D3 EMS1



This is a Small size soft starter with DIN-Rail mounting feature ideally suitable for light duty small motor applications

D3 EMS1 Controls voltage of 2 phases, with facility for adjusting Soft Start, Soft Stop times and Starting Torque.



Power Range (KW / HP)	1.5 KW / 2 HP, 2.2 KW / 3 HP, 3.7 KW / 5 HP
Nominal Current (Amp)	8 Amps. Max.
Control. Supply Voltage	24-110V AC/DC (+15% - 20%) 110-415V AC (+15% - 20%)
System Supply	415V AC + 15% - 20%
Line Frequency	50/60 Hz ± 3%
Bypass facility	Built-in (Via Internal Contactor Relay)
Start Mode	Reduced Volt Start
Current Limit % In (FLA)	N.A.
Ramp Up Time (Sec.)	Adjustable from 0.5 to 10 Sec.(±25%)
Ramp Down Time (Sec.)	Adjustable from 0.5 to 10 Sec.(±25%)
Initial Torque	0% - 80%
Protections	N.A.
Operating Temp.	0°C to 45°C
Device Dimensions (mm)	Overall (L x W x D) 76 x 82 x 115 (mm)
Weight in Kgs (Approx.)	340 gms (approx.)
Communication	N.A.
Protocol	N.A.

With this soft starter 3-phase motors with nominal load currents upto 8 A can be soft-started and / or soft-stopped, thus reducing the inrush current and eliminating the damaging effects of high starting current surges. This is a compact starting device for small motors and hence there is room for more products on a given mounting platform. It is easy to install and to adjust because access for connections and adjustments is from the front. Starting and stopping time as well as initial torque can be independently adjusted by built-in potentiometers.

FEATURES

- 1) Reduced inrush current and mechanical shock
- 2) Soft, smooth, step-less acceleration & deceleration
- 3) Soft Start Time, Soft Stop Time, Initial Torque independently settable by means of potentiometer
- 4) Built-in bypass relay (For bypassing SCR)
- 5) Easy to install and operate
- 6) Millions of switching cycles
- 7) Compact, lightweight
- 8) DIN-rail mounting (35mm)
- 9) LED indications for 3-ph ON, Ramp up / Ramp down and Run

CONTROL AND SETTINGS

D3EMS 1 has three potentiometers control on its front.

- 1) Ramp up: To set ramp up time (0.5 to 10 Sec.)
- 2) Ramp down: To set ramp down time (0.5 to 10 Sec.)
- 3) Initial torque: To set initial torque of the motor (0 to 80%)

Set Ramp - up time and Initial Torque such that motor will start without jerk and humming noise.

FUNCTIONAL DESCRIPTION

Soft Start : During ramp-up, the soft starter will gradually increase the voltage to the motor until it reaches full line voltage. The motor speed will depend on the actual load on the motor shaft.

Initial Torque : The initial torque is used to set starting voltage. This way it is possible to adapt the soft starter to an application requiring a higher starting torque. It can be adjusted from 0 to 80% of nominal torque.

Softstop : During ramp-down, Soft starter gradually reduce the voltage to the motor thus reducing the torque and current. The soft stop feature is advantageous to avoid water hammering and cavitation on pumps and to avoid goods tilting on conveyors. It is typically used on motor application where a smooth start and / or stop is advantageous there by reduce the wear on gear and belt / chain drives. It is used for light duty applications such as small conveyors, bottle washers, pump-bore, slicer etc.

PROTECTION

This unit does not provide any protection, Hence user has to take care of necessary protections.

